



TW-759-1 **ASW28**

Specification

Wing Span:	2540mm (63")
Length:	1132mm (41.1")
Flying Weight:	1050g
Battery:	11.1V/1500mAh / 20C
Motor:	Brushless 850KV
ESC:	30A Brushless ESC
Radio:	2.4G 6-Channel Proportional Control
Range:	600m

This airplane is not a toy, but rather a sophisticated working model that functions very much like a full size airplane. Because of its performance capabilities, the plane, if not assembled and operated correctly could possibly cause injury to yourself or spectators and damage property.

Keep items that could become entangled away from the rotating propeller, including loose clothing and tools etc. Be especially sure to keep your hands, face and other parts of your body away from the propeller blades.

As the user of this product you are solely and wholly responsible for oper-

ating it in a manner that does not endanger yourself and others or result in damage to the property of others.

You must assemble the model according to the instructions. Do not alter or

modify the model in anyway, as doing so may result in an unsafe or unflyable model. In a few cases the instructions may differ slightly from the photos due to updates. In these instances the written instructions should be considered as correct.

If you are not an experienced pilot or have not flown this type of model before, we recommend that you get the assistance of an experienced pilot in your R/C club for your first flight. If you are not a member of a club, your local hobby shop should have information about clubs in your area whose membership includes experienced pilots.

This model has been flown and flight tested to beyond normal limits, but if the plane is used for extreme and high stress flying such as racing , or if a motor larger than the one in the recommended range is used, the modeler is responsible for taking steps to reinforce the high stress points and / or substituting hardware more suitable for the increased stresses.

We , as the kit manufacturer have provided you with a top quality, thoroughly tested kit and instructions, but ultimately the quality and flyability of your finished model depends on how you build it. Therefore, we cannot in any way guarantee the performance of your completed model, and no representations are expressed or implied as to the performance or safety of your completed model.

Kit Contents

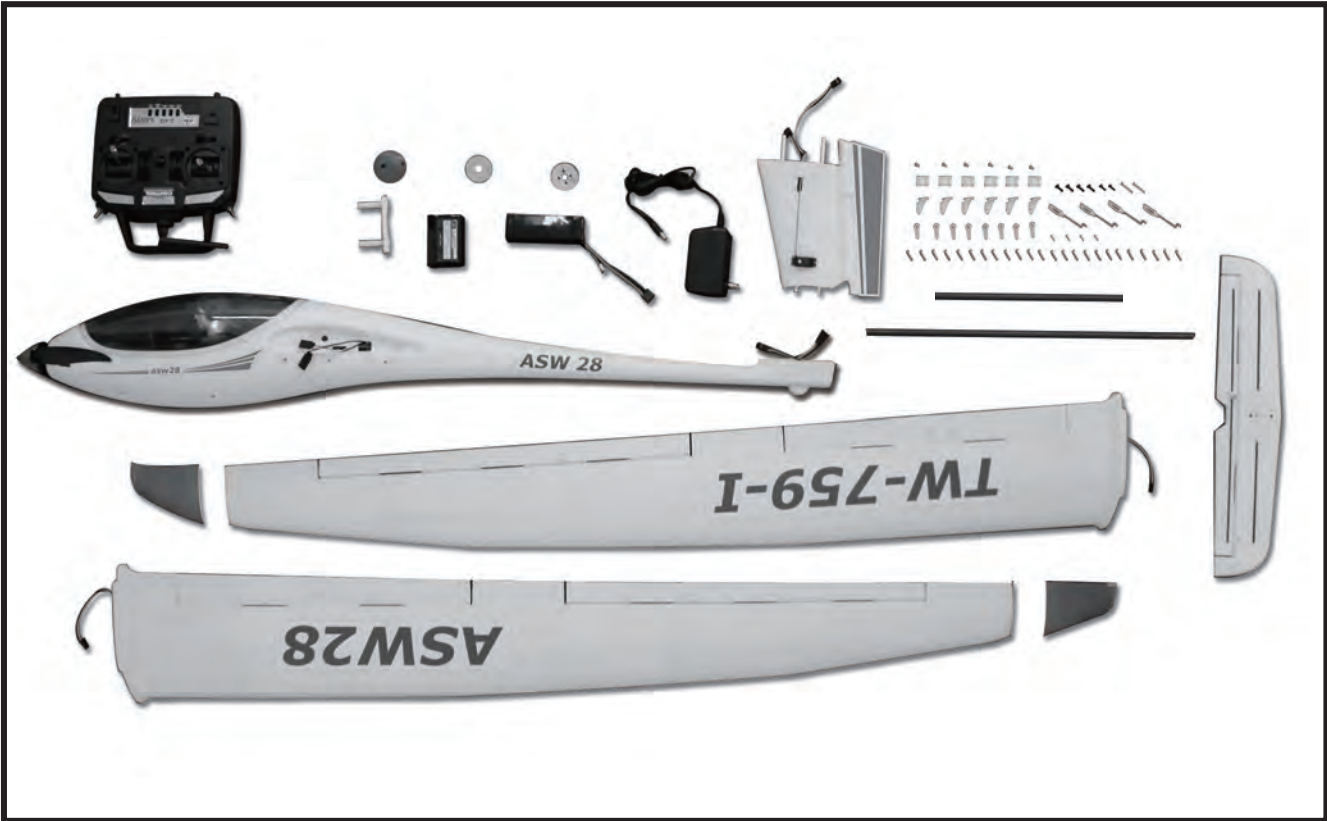

Assemble The Plane

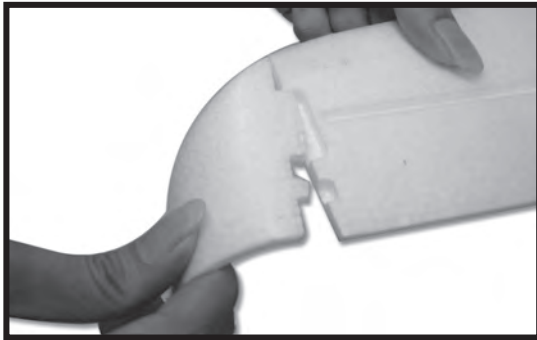
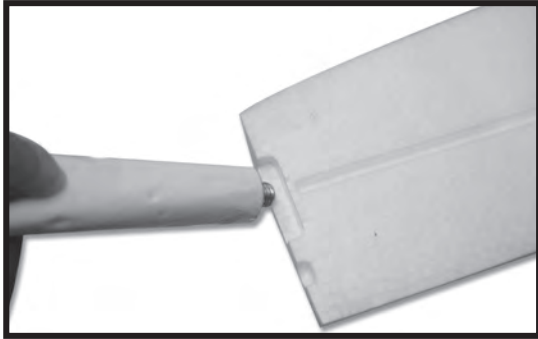

2. Glue the wingtip to the main wing.

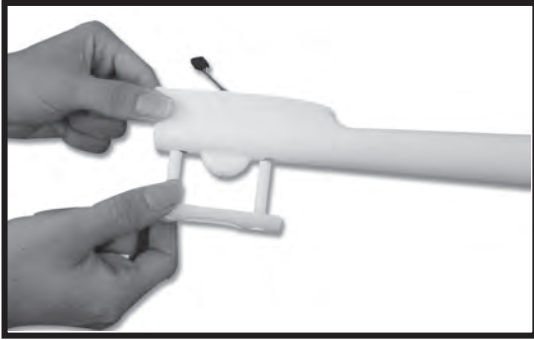

3. Insert the fin joiner into the corresponding holes in the rear of the fuselage.

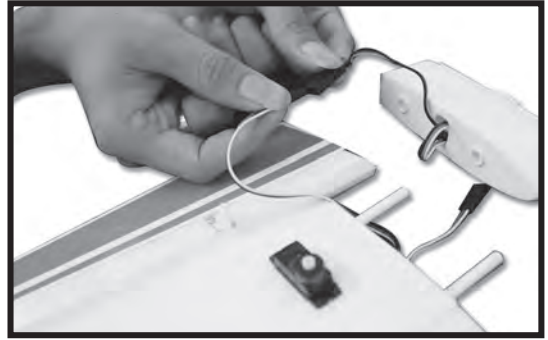

4. Connect the servo wire to the extension lead.



5. Install the fin to the fuselage with the screw provided.

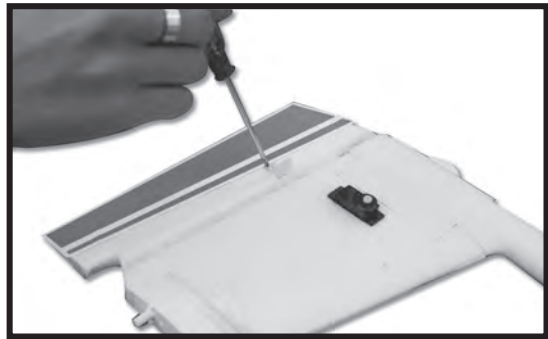
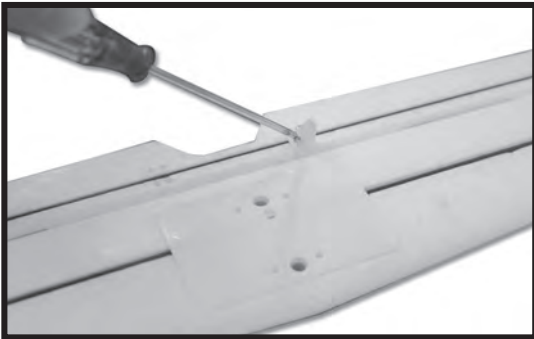

6. Install all the servo horns using the screws provided.

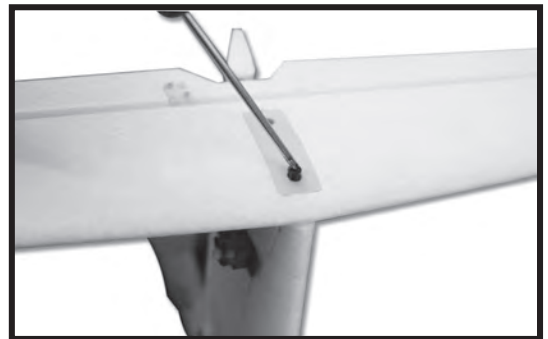

7. Install the tailplane to the fin using the screw provided.

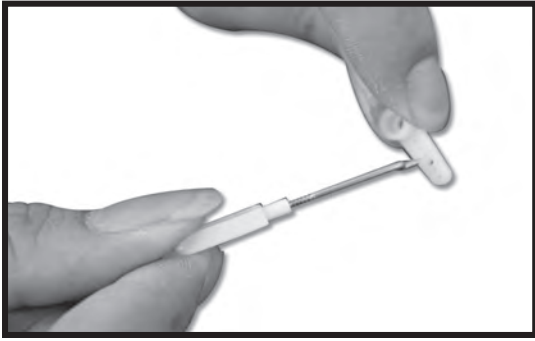

8. Connect the pushrod to the rudder servo arm.

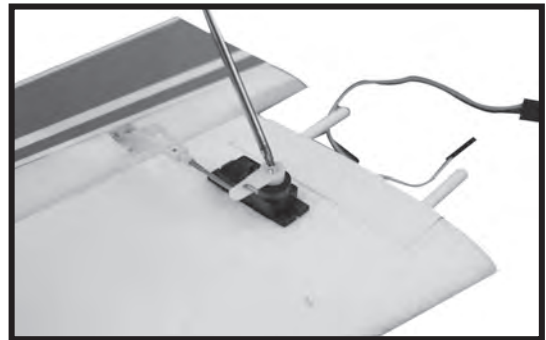

9. Connect the pushrod to the servo arm and fix the servo arm to the rudder servo with a screw (do not connect the pushrod to the horn at this point)

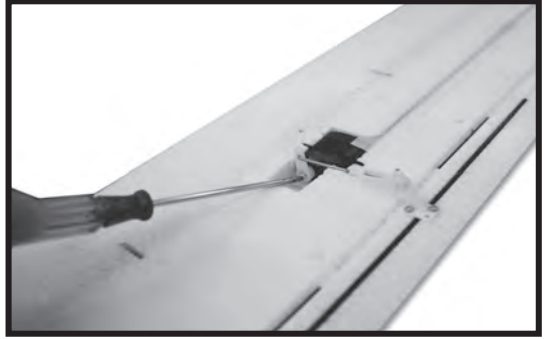

10. Connect the aileron pushrods to the servo arms and fix the servo arms with a screw, (do not connect the pushrods to the horns at this point)



11. Insert the metal wing joiners to the main wing.

12. Put the metal joiners through the corresponding hole of the fuselage and connect the servo wires of the ailerons and flaps.

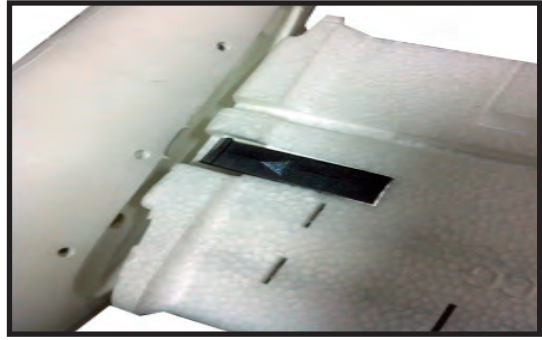

13. Connect the main wings to the fuselage using the plastic clips. Ensure that hear and feel a sound “click” when fitting the main wings to the fuselage, this tells you that the wings have located properly.



14. Plug in the battery then secure the canopy.

Centering the Control Surfaces

With the transmitter turned on and the LiPo flight battery connected to the ESC (and installed in the battery compartment) it's now possible to connect the pushrods to the rudder and elevator control surfaces and to 'center' the surfaces accordingly.

Firstly, be sure to center the elevator and rudder (aileron) trim levers. Press the trim button till it has a short and big drop sound, (a long and big drop sound means you reach the end of the trim in one side).

With the trim levers centered, carefully spread open each 'clevis' (the white color plastic part installed on the threaded end of the metal pushrod) so you can insert the pin in the OUTERMOST hole on each control horn. It may be helpful to insert a flat blade screwdriver (not included) into the clevis then carefully 'twist' it until it disengages the pin from the hole in the clevis. Also, it is not necessary to 'snap' the clevis back together until the centering adjustments are complete.



After connecting the clevises to the control horns view the vertical tail and rudder from directly above. The rudder should be 'in line' with the vertical tail when it's properly 'centered'. However, if the rudder is angled off to the right or left you can adjust the length/position of the pushrod/clevis so the surface is centered 'mechanically' while the trim lever on the transmitter is centered.

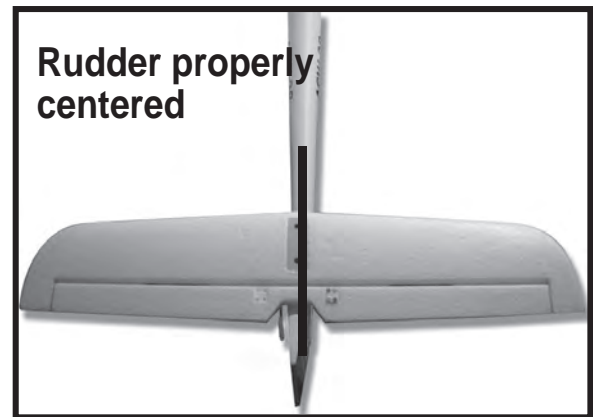
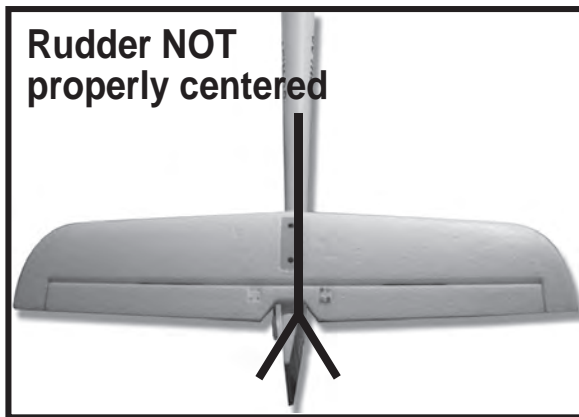

If the rudder is angled off to the left carefully remove the clevis from the control horn and screw it 'in' (clockwise) one half to one full turn then insert the pin back into the outermost hole in the control horn. Or, if the rudder is angled off to the right carefully remove the clevis from the control horn and screw it 'out' (counter-clockwise) one half to one full turn then insert the pin back into the outermost hole in the control horn.

View the vertical tail and rudder from directly above again and continue adjusting the length/position of the pushrod/ clevis until the rudder is centered appropriately.

NOTE: You should always rotate the clevis until the pin is perpendicular with the control horn to ensure the pin is not under any excessive load/ pressure when inserted in the hole and during operation. In some cases it may not be possible to 'exactly' center the surface mechanically while properly aligning the pin. In these cases be sure the pin is properly aligned then adjust the position of the trim lever slightly as needed. Also, it will likely be necessary to make

further adjustments to the position of the trim lever during flight as most surfaces do not end up in exactly the centered position when an airplane is trimmed properly for actual flight (but 'centered' is still the best starting point).

Follow the same steps outlined for centering the rudder to center the elevator (and aileron) as well.

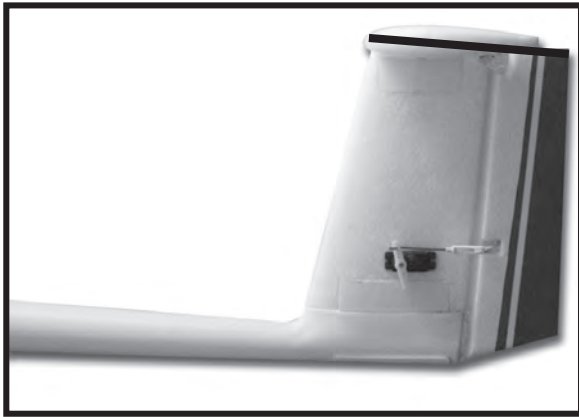

Also, we strongly recommend installing the included 'clevis keepers' to provide added security for the clevises. Typically you can carefully slide the keepers over the clevises when they are not connected to the control horn. Then, after connecting the clevis to the control horn and 'snapping' the clevis together you can slide the keepers into a position that does not allow them to 'bind' against the control horn during movement of the surface.

Center of Gravity

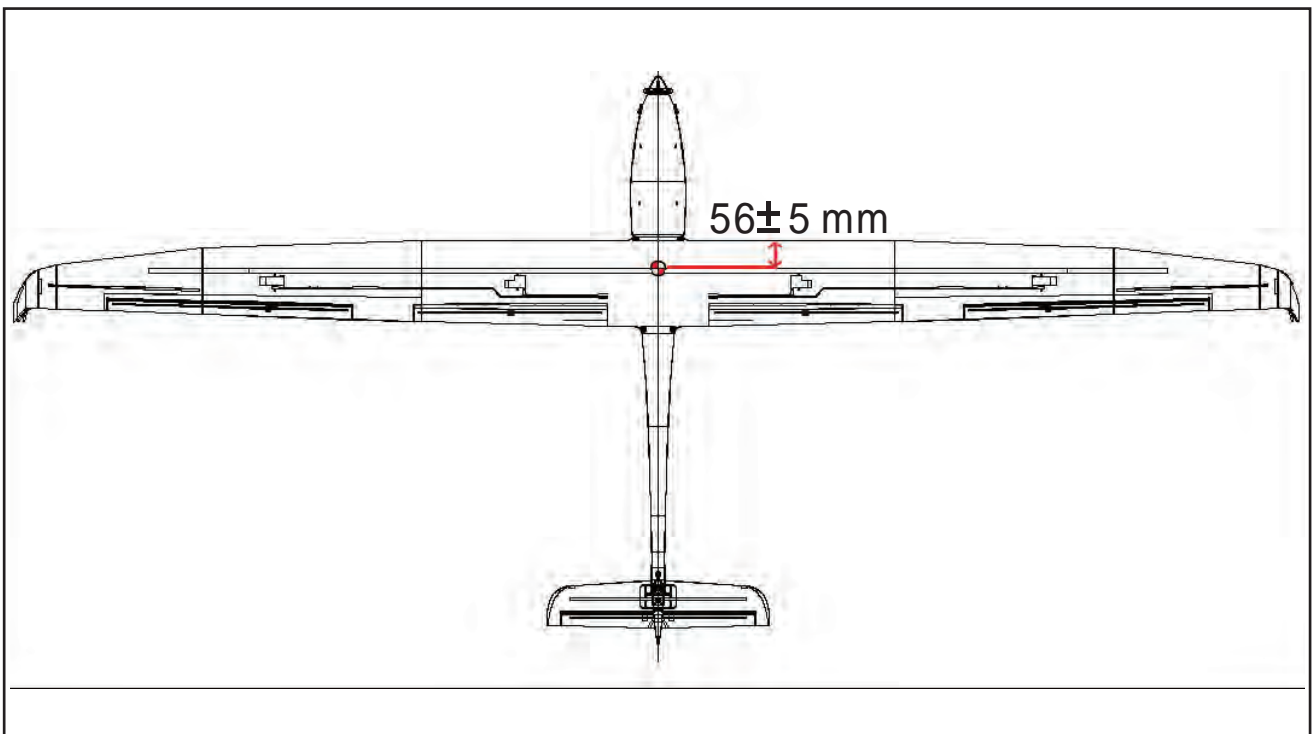

The ideal C of G position is 56mm behind the leading edge measured at where the wing meets the fuselage (you can safely be + or - 5mm either side of this measurement). The C of G has a GREAT effect on the way the model flies. If the C of G is too far aft (tail heavy), the model will be too responsive and difficult to control. If the C of G is too far forward (nose-heavy), the model will be too stable and not re-sponsive enough. In order to obtain the correct C of G as specified, add weight to the fuselage or move the battery position. Check the C of G before you fly.

Battery Warnings

IMPORTANT NOTE: Lithium Polymer (LiPo) batteries are significantly more volatile than alkaline, NiCd or NiMH batteries which are also used in RC applications. All instructions and warnings must be followed exactly to prevent property damage and/ or personal injury as mishandling of LiPo batteries can result in fire.

By handling, charging or using the included LiPo battery you assume all risks associated with LiPo batteries. If you do not agree with these conditions, please return your complete product in new, unused condition to the place of purchase immediately.

You must read the following safety instructions and warnings before handling, charging or using the LiPo battery.

- You must charge the LiPo battery in a safe area away from flammable materials.
- Never charge the LiPo battery unattended at any time. When charging the battery you should always monitor the charging process and react immediately to any potential problems that may occur.
- After flying / discharging the battery you must allow it to cool to ambient / room temperature before recharging. Also, it is NOT necessary or recommended to discharge the battery 'completely' before charging (LiPo batteries have no 'memory' and it's safe to charge partially discharged batteries when using an appropriate charger that is set correctly).

- To charge the battery you must use only use the included Charger or a suitable compatible LiPo battery charger. Failure to do so may result in a fire causing property damage and/ or personal injury. DO NOT use a NiCd or NiMH charger to charge Li-Po batteries.
- If at any time during the charge or discharge process the battery begins to balloon or swell, discontinue charging or discharging immediately. Quickly and safely disconnect the battery then place it in a safe, open area away from flammable materials to observe it for at least 15 minutes. Continuing to charge or discharge a battery that has begun to balloon or swell can result in a fire. A battery that has ballooned or swollen even a small amount must be removed from service completely and not used anymore. Dispose of as per regulations.
- Store the battery partially charged (approximately 50% charged/3.85V per cell), at room temperature (approximately 68–77° Fahrenheit [F]) and in a dry area for best results.
- When transporting or temporarily storing the battery, the temperature range should be from approximately 40–100°F. Do not store the battery or model in a hot car or direct sunlight whenever possible. If stored in a hot garage or car the battery can be damaged or even catch fire.
- Do not over discharge the LiPo flight battery. Discharging the LiPo flight battery to a voltage that is too low can cause damage to the battery resulting in reduced power, flight duration or failure of the battery entirely. If this happens usually you will not be able to recharge the battery, do not try forcing a charge into it as this could cause the battery to swell and catch fire.
- LiPo cells should not be discharged below 3.0V each under load. In the case of the 2-Cell/ 2S 7.4V LiPo battery used to power the plane you will not want to allow the battery to fall below 6.0V during flight.

The included ESC features a 'soft' low voltage cutoff (LVC) that smoothly reduces power to the motor (regardless of the power level you have set with the throttle stick) to let you know the voltage of the battery is close to the 6.0V minimum.

However, even before this reduction in power, if you find that more than the typical amount of throttle/ power is required to cruise or climb you should land the model and disconnect the battery immediately to prevent over-discharge.

And while it is possible to continue flying the model after the soft LVC occurs, this is NOT recommended. Continued discharging can result in reaching the 5.0V 'hard' LVC which may cause permanent damage to the LiPo battery resulting in reduced power and flight duration during subsequent flights (or failure of the battery entirely which is not covered under warranty).

Also, it is not recommended that you fly to the soft LVC every time you fly. Instead you should be aware of the power level of the battery / airplane throughout the flight, and if at any time the airplane begins to require more throttle/ power than typical to maintain cruise or climb you should land the airplane and disconnect

the LiPo battery immediately. Constantly discharging the battery to the soft LVC can still cause permanent damage to the battery so it's best to use a timer or stop-watch to time the duration of your flights and to stop flying at a reasonable time before the soft LVC is reached.

IMPORTANT NOTE: DO NOT LEAVE THE LIPO BATTERY CONNECTED TO THE ESC UNLESS YOU ARE READY TO FLY. IF THE BATTERY IS LEFT CONNECTED TO THE ESC WHEN IT IS NOT IN USE THE LIPO BATTERY WILL BE OVER-DISCHARGED BY THE SMALL AMOUNT OF CURRENT THE ESC CONSUMES.

It can sometimes take a few hours or even up to a few days to over-discharge the battery this way but doing so will likely cause permanent damage to or failure of the battery entirely (which is not covered under warranty).

IMPORTANT NOTE: DO NOT STORE THE LIPO FLIGHT BATTERY FULLY CHARGED. For improved safety and longevity of the LiPo battery it's best to store it only partially charged for any length of time. Storing the LiPo battery at approximately 50% charged (which is approximately 3.85V per cell) is typically best, however it will take some careful management of the charge time and the use of a voltmeter to achieve this voltage.

If you have the equipment and skills to achieve the 50% charge level for storage it is recommended. If not, simply be sure to not store the battery fully charged whenever possible. In fact, as long as the battery will be stored at approximately room temperature and for no more than a few weeks before the next use, it may be best to store the battery in the discharged state after the last flight (as long as the battery was not over-discharged on the last flight).

Transmitter Instruction

Mode 1 and Mode 2

Depending on which area you are in, you will either use a Mode1 or Mode 2 transmitter. The difference between the two modes is that the throttle and Elevator stick are transposed. Mode 2 transmitters have the throttle control on the left stick and the Elevator controls on the right stick. Mode 1 is in the opposite way.

Mode 1 (left throttle)

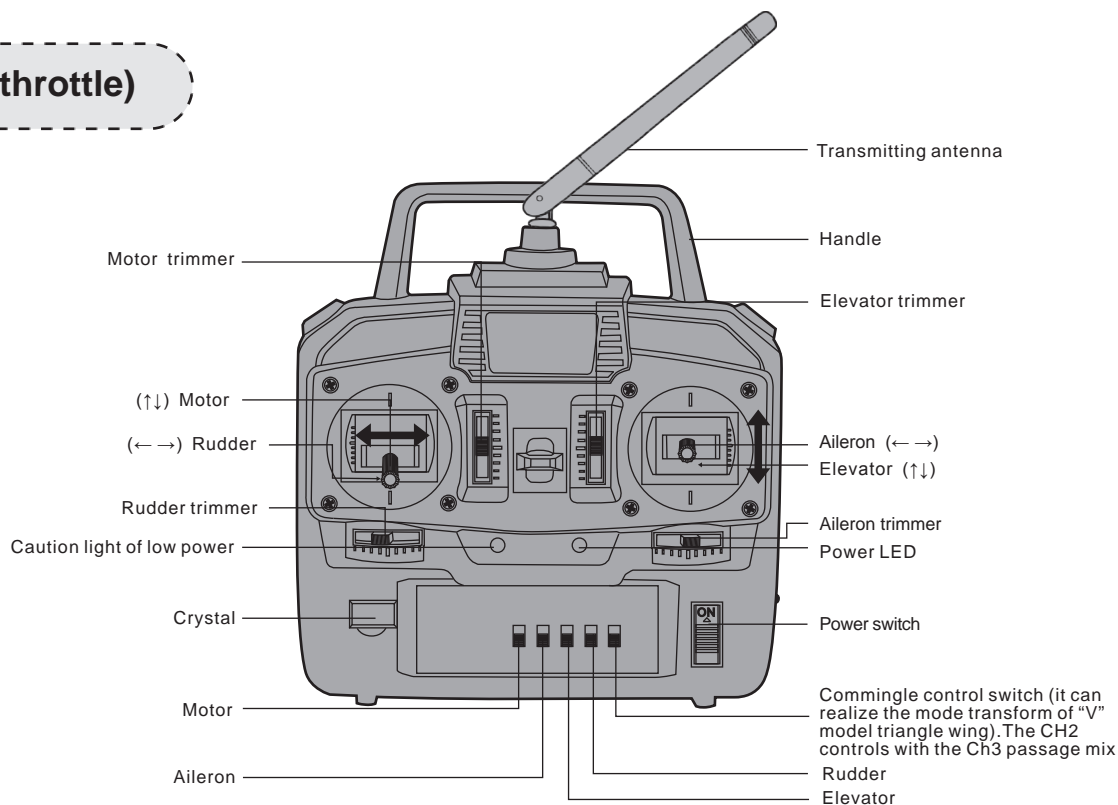

Mode 2 (Right throttle)

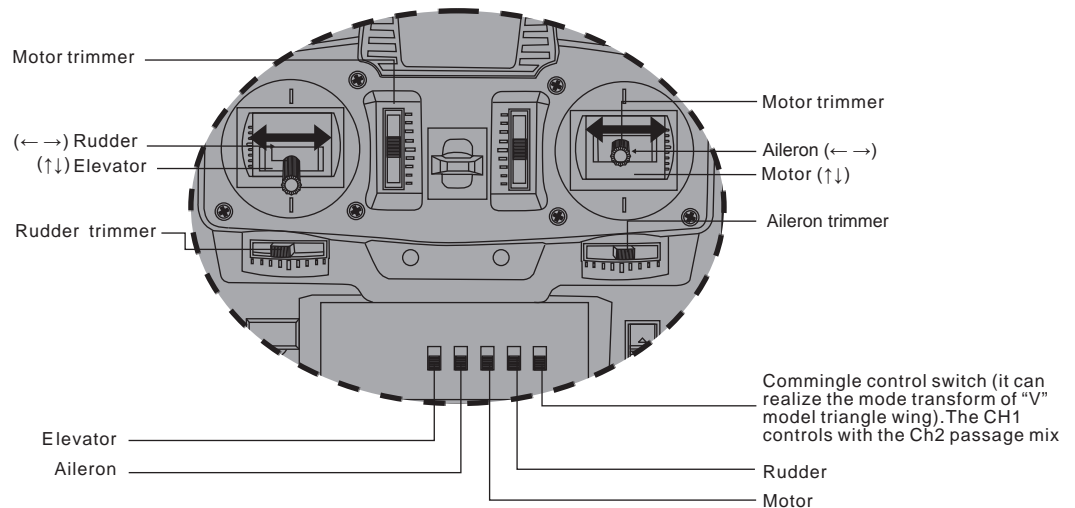

Low Battery Voltage/Power Indication

When the AA battery voltage / power drops to a level that's too low for safe continued operation, the red color LED indicator will begin flashing. DO NOT use the transmitter or fly when the red LED indicator is flashing and immediately install new AA batteries before using the transmitter or flying.

Control / Servo Reversing

The transmitter features control/ servo reversing functionality for the aileron, elevator, throttle and rudder channels. The control / servo directions were set correctly at the factory for the plane, however, in case the controls are operating in the wrong direction, or you use the electronics in other models later on, simply change the position of 'Servo Reverse' switch for the channel(s) as needed. Thoroughly check that the controls are operating in the correct sense BEFORE you fly.

Delta / Elevon Mixing

Located to the right of the 'Servo Reverse' switches is a switch that activates / deactivates the optional-use 'Delta / Elevon' mixing. No such mixing is used for this model so please be sure this switch is in the OFF / lower position (failure to do so will result in improper control and the inability to fly the plane). However, if using this transmitter with 'flying wing', delta or other airplanes that 'combine (mix)' the elevator and aileron (often known as 'elevon') controls you can move the switch to the ON/upper position.

To bind the receiver

1. Move the throttle stick to the bottom.
2. Turn on the transmitter.
3. Connect the battery to the receiver.
4. Press the bind button of the receiver. (the LED of the receiver will flash quickly)
5. When the LED stops flashing and stays on the bind is successful.

Cautions

Pls make sure the throttle joystick is at the bottom position when you bind the receiver and before you connect the battery in the model. Please remove the propeller before binding the receiver as the motor might inadvertently start and cause injury.

Check The Control Surface and Channel Condition

Before trying to fly the airplane, please carefully check to make sure the transmitter and the servos work normally. **CAUTION: Make sure that you turn on the transmitter first and only then connect the battery plug. If you want to turn off the transmitter you must ensure that the battery in the model is disconnected first.**

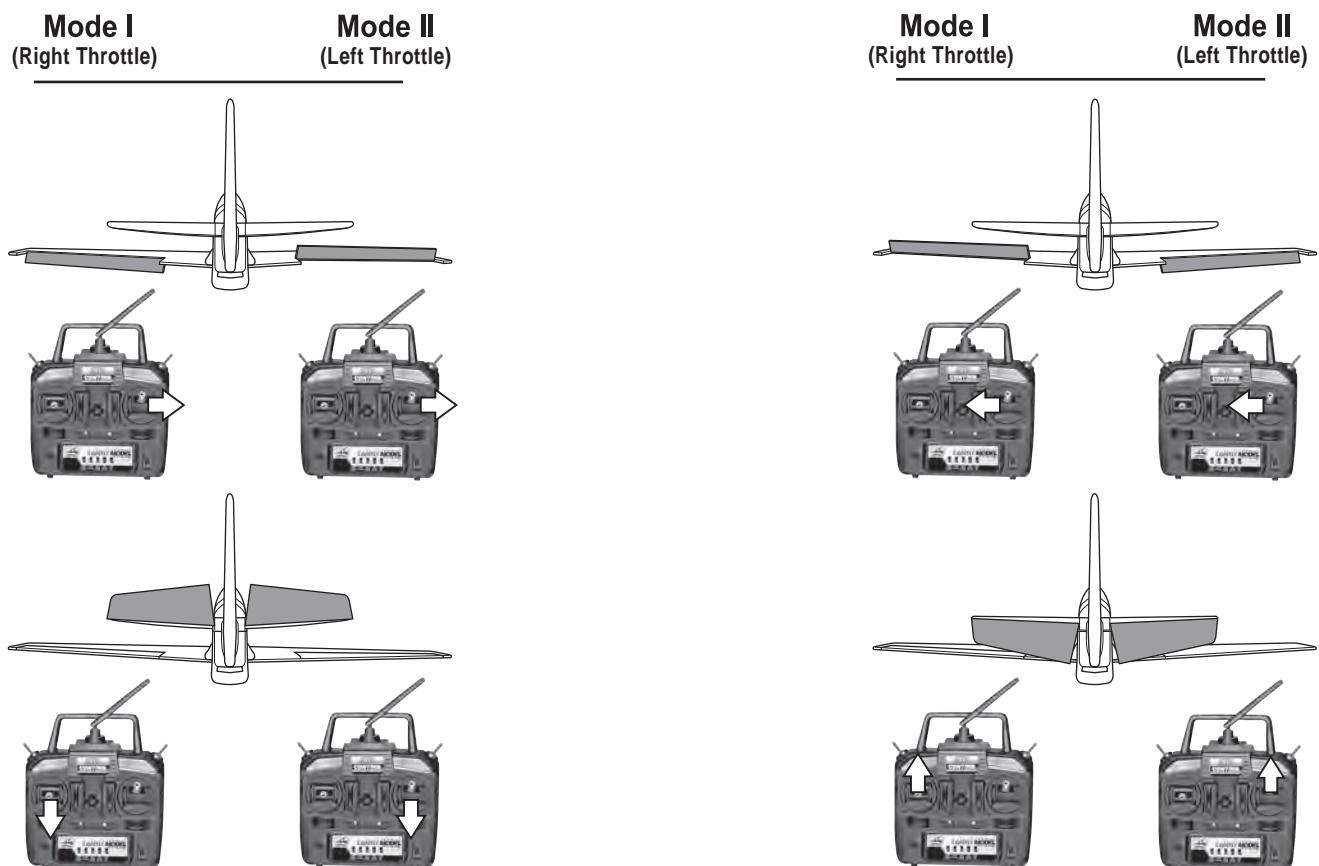

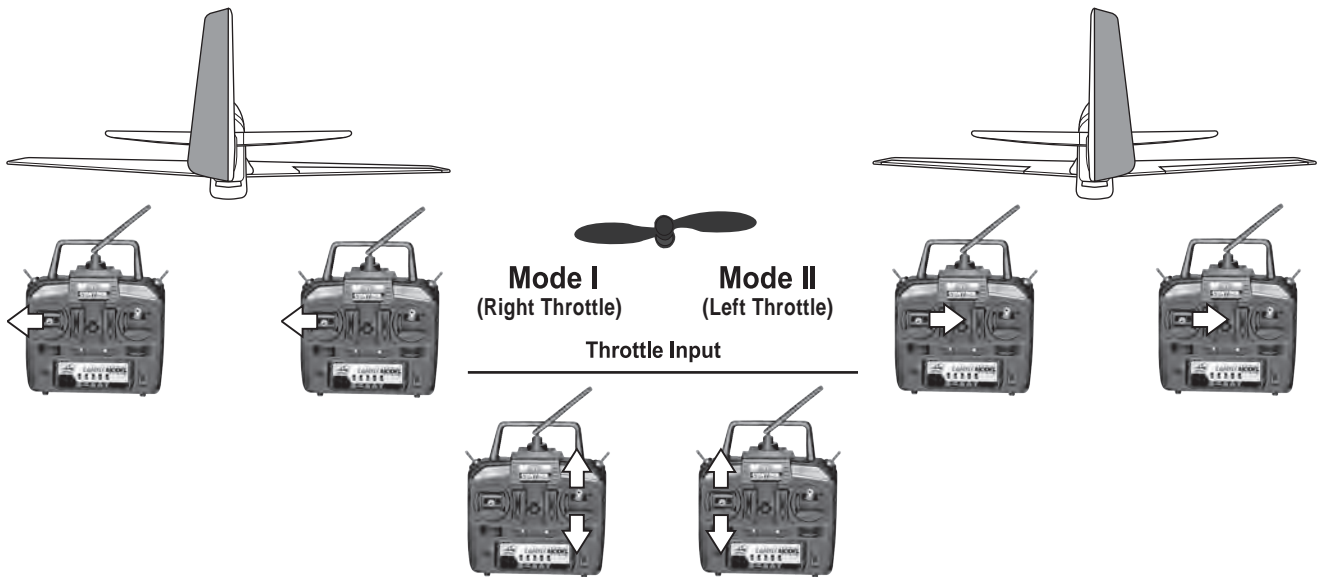

Know Your Frequency

Based on the size and weight of the plane it's typically considered to be a 'park flyer' class model. As a result it's best to fly the plane at a local park, schoolyard, flying field or other area that's large enough and free of people and obstructions. We recommend an area the size of at least one football/ soccer field, however, even larger areas are better suited and preferred especially when learning how to fly. **DO NOT fly in parking lots, crowded neighborhood areas or in areas that are not free of people and obstructions.**

We also suggest flying over grass as it's a much more forgiving surface that causes less damage in the unfortunate event of a crash. Short grass is better for landings as grass that is too long can cause the airplane to nose over or flip and be damaged.

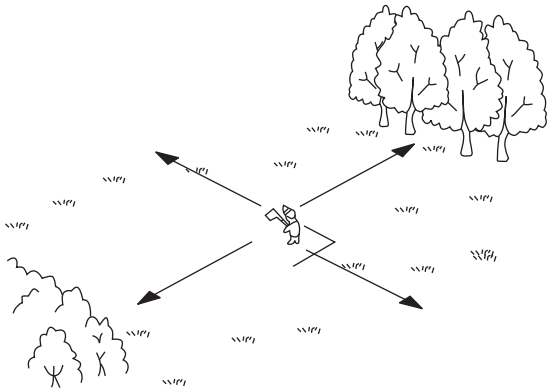

Fly in a spacious area without obstacles, or near power lines or roads or near crowds of people or spectators.

PLEASE NOTE: The plane is designed to be flown outdoors only.

Flying Conditions

It's typically best to fly on days that are calm with no wind, especially when learning how to fly. We strongly suggest flying only in calm conditions until you're familiar with the controls and handling of the model. Even light winds can make it much more difficult to learn to fly, and in some cases can even carry the model beyond your line of sight.

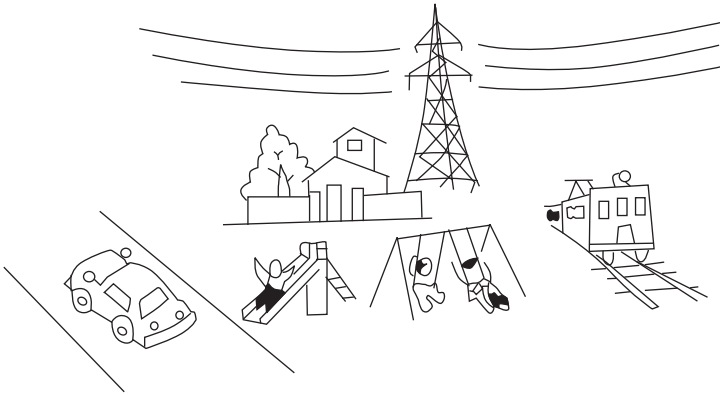

As a reminder, never fly the plane near highways, railways, high tension power line, crowds of people and residential areas.

Also, if you are a first-time or low-time pilot we highly recommend allowing a more experienced pilot to test fly and properly trim the model before attempting your first flight. A proven flyable and properly trimmed model is significantly easier and more enjoyable to fly! Please contact your local hobby shop and/or flying club to find a more experienced pilot near you.

After you've properly trimmed the airplane in calm conditions and become familiar with its handling capabilities you'll be able to fly in light winds, or depending on your experience and comfort level, in winds up to 5–7 mph.

DO NOT fly on days when significant moisture, such as rain or snow, is present.

Flight Checklist

PLEASE NOTE: This checklist is NOT intended to replace the content included in this instruction manual. Although it can be used as a quick start guide, we strongly suggest reading through this manual completely before proceeding.

- Always turn the transmitter on first
- Ensure the throttle control stick is in the bottom position before plugging in the battery.
- Hand launch the model with a firm, level throw over a grass field.
- Land the model ideally on a short grass field.
- Unplug the LiPo flight battery from the ESC when you have finished flying.
- Always turn the transmitter off last

Know Your Frequency

CAUTION: The transmitter used to control your plane transmits signals on one of several frequencies that are available. To find out your frequency (or “channel”), look on the transmitter. If your “channel” happens to be the same as another model that is being flown nearby (even within a few miles), one or both models will crash. Know your frequency and be aware of the frequency of other models that are flying nearby, especially if you are flying at a radio control flying site. All flying sites have some sort of frequency control system to avoid this kind of interference, so learn how to use their frequency control system. Never turn on your transmitter until you are certain that you will be the only one operating on your frequency.

Perform a Range Check

As a precaution, an operational ground range test should be performed before the first flight each time out. performing a range test is a good way to detect problems that could cause loss of control such as low batteries defective or damaged radio components or radio interference. This usually requires an assistant and should be done at the actual flying site you will be using.

First turn on the transmitter. Then, install the fully charged battery into the fuselage and hold it in place with the hook-and-loop strap. Connect the battery and install the canopy.

Remember, use care not to “knock” the throttle stick, if you do “knock” the stick the motor will start and the propeller will most likely cause damage or injury.

With the antenna on the transmitter collapsed (not extended), begin walking away from the model operating the controls in a predictable pattern (for example: Up, then down elevator. Right, then left aileron. Right, then left rudder). While moving the control surfaces, also vary motor rpm.

Have your assistant alert you if the controls fail to respond or if they move suddenly or erratically. You should be able to maintain control up to a distance of approximately 100' [30m].

If the controls respond erratically or if anything else seems wrong, make certain all the servo wires are securely connected to the receiver and that the transmitter and receiver batteries are fully charged. If you cannot find a mechanical problem with the model, it is slightly possible that there is radio interference in the area. One option would be to try another range check at an alternate flying site.

After the range check, fully extend the antenna.

Monitor and limit your flight time using a timer such as the one on your wrist watch. When the batteries are getting low you will usually notice a performance drop before the ESC cuts off the motor power, when you notice the plane flying slower you should land. Often (but not always!), power can be briefly restored after the motor cuts off by holding the throttle stick all the way down for a few seconds.

To avoid an unexpected dead-stick landing on your first flight set your timer to a conservative 4 minutes. When the alarm sounds you should land your model.

When you learn how much flight time you are getting you can adjust your timer accordingly. Always be conservative so the motor won't quit unexpectedly and you will have enough battery to land with power still available if required..

Take Off

Until you have become comfortable with flying your plane, do not fly if the wind speed **that** is greater than 10 mph [16 kilometers / hr].

One final check before takeoff : always double - check the flight control response to your inputs from the transmitter before every flight. Be certain the ailerons , elevator and rudder respond correctly and that none of the controls have inadvertently become reversed.

Don' t forget to fully extend the transmitter antenna.

Fly the model over a field of ideally short grass and one that has no obstructions.

Take off (**Hand launch**)

Ideally have a helper hand launch the model for you. Have them hold the model under the wing somewhere close to the C of G position, point it into wind and hold the model just above shoulder height. The pilot should then call out that he is starting the motor, he should then smoothly open the power up to full throttle, the launch person should then launch the model with a firm, level throw making sure that the wings are also level, DO NOT launch the model upwards as it may stall and crash. Fly the model level with the ground until sufficient flying speed has been attained and only then ease it into a gentle climb.

Keep flying straight into wind until at least 50/75ft, only then should you attempt a gentle turn away from the take off line. Keep climbing a bit more until you are around 150ft, then throttle back to somewhere between half and three quarters throttle so that the model stops climbing and then get used to some gentle turns after first trimming the model (see further on).

One thing to remember is that, when the plane is flying away from you, moving the aileron stick to the right will make the plane bank to your right.

However, when the model is flying toward you, moving the aileron stick to the right will make the plane move to your left. Of course, the plane is still responding the same way, it's just that your orientation has reversed. This must be kept in mind while learning to fly (and is also a good reason to take flight lessons from an experienced pilot!).

To establish a turn gently apply some aileron in the direction you want the model to bank, once it is at the required angle of bank almost centralise the ailerons, leave just a small amount in the direction of the turn, a small amount of up elevator will be required to maintain the correct attitude and to stop a spiral dive developing.. To stop the turn move the aileron stick in the opposite direction, centralise the stick when the wings are level and remove any up elevator you may still be holding in.

Once you get the plane into the air and have climbed to a comfortable altitude, the first "order of business" will be to "trim" the model for straight - and - level flight. The model flies best at approximately 3/4-throttle. Adjust the trims on the transmitter to make minor control surface adjustments as necessary until the plane will fly straight and without climbing or descending without any stick inputs at all. If necessary ask your helper to adjust the trims for you whilst you are flying. A well trimmed model is much easier to fly than a model that is out of trim, take your time to get this exercise correct.

Remember to keep the model high enough to give yourself time to make corrections, but don't let it get too far away. Otherwise, it will be difficult to detect its attitude and which way it is going.

One final check before landing is to see how the model will react when it's time to land and you cut the power. To do this, while still at altitude, cut the motor power, the model should establish a gentle, downward glide path.

This is how the model will react when it's actually time to land. Add power and climb back up to your original altitude, throttle back then try the exercise again.

Practice a few of these "climb and glides" to judge how far out you will need to be when its time to land.

Landing

To land, fly downwind and off to one side past the landing area at about 75/100ft. Gently turn across the wind and take a bit of power off so that the model gently descends. Just before you are in line with the landing area turn into wind and reduce power some more, you should now be on approach to the landing area and gently descending. If you think you are going to undershoot the landing area then add a small amount of power, if you think you are a bit high and will overshoot the landing area then take power off or even close the throttle completely. Keep the wings level and the nose pointing into wind at all times, if the model has been trimmed correctly it will be descending nicely to the landing area. Once about head high close the throttle completely if you have not already done so, then apply a very small amount of up elevator until you are about 2ft from the ground, gently apply more up elevator as the model slows and gets nearer the ground, by the time the model touches the ground you should have almost full up elevator. Once again make sure you keep the wings level at all times near the ground.

Later, once you have become more experienced with your plane, you can cruise around and perform slow "fly-bys".

CAUTION: If, during a rough landing, the propeller becomes jammed and cannot rotate, the battery and speed control will become very hot if you attempt to add power. Immediately move the throttle down to stop the motor. If you fail to do this, the motor, speed control and /or battery will be damaged.

After flight

Disconnect the battery and remove it from the airplane. Then, turn off the transmitter. Allow the battery to cool before recharging, or allow the motor to cool before installing another battery for the next flight. Inspect the airplane to make sure nothing has become loose or damaged.

VOLANTEX RC

PRODUCED, DESIGNED
AND BACKED BY **EXIHOBBY**